

Rod Ends Overview



R3550, R3553 Male plain bearing rod ends



R3551, R3554 Female plain bearing rod ends



R3556, R3559 Male ball bearing rod ends



R3557, R3560 Female ball bearing rod ends



R3562 Male roller bearing rod ends



R3563 Female roller bearing rod ends



R3565, R3577 Male Stainless Steel rod ends



R3566, R3576 Female Stainless Steel rod ends



R3570 Female low cost rod ends



R3571 Male low costs rod ends



R3579, R3582 Female plastic rod ends



R3580, R3583 Male low cost rod ends

Rod Ends

Heavy-Duty Rod Ends - Male with integral spherical plain bearing in Stainless



R3565

y

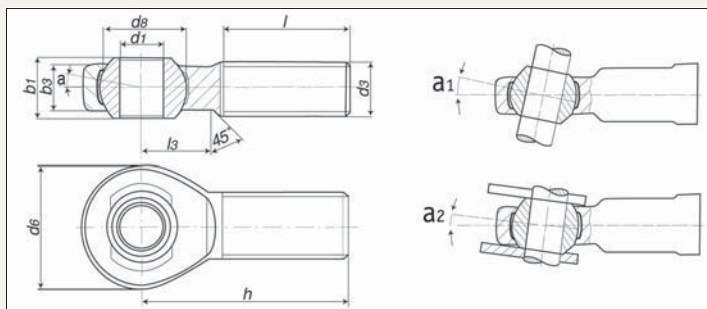

Material

Rod end housing: **Stainless Steel** DIN 1.4301 (AISI 304), forged, rolled thread

Joint ball: **Stainless Steel** 1.4412, hardened and ground, surface superfinished.

Race: Nylon/Teflon/glass compound.

Technical Notes

Male thread.
Maintenance free.
For tolerances see technical pages.

Standard thread is Right hand thread.

Tips

A2 **Stainless Steel** provides good corrosion resistance to a wide range of

atmospheric conditions and corrosive media. It is considered resistant to potable water.

Important Notes

*Denotes fine pitch thread.
Further technical data on next page.

Heavy-Duty Rod Ends - Male with integral spherical plain bearing in Stainless

Rod Ends

| Order No. | Thread (hand) | d ₁ | d ₃ | d ₆ | d ₈ | b ₁ | b ₃ | h | $\frac{\Delta}{g}$ |
|------------|---------------|----------------|----------------|----------------|----------------|----------------|----------------|-----|--------------------|
| R3565.R005 | Right | 5 | M5 | 18 | 11,06 | 8 | 6,00 | 33 | 14 |
| R3565.R006 | Right | 6 | M6 | 20 | 12,65 | 9 | 6,75 | 36 | 20 |
| R3565.R008 | Right | 8 | M8 | 24 | 15,85 | 12 | 9,00 | 42 | 38 |
| R3565.R010 | Right | 10 | M10 | 28 | 19,00 | 14 | 10,50 | 48 | 60 |
| R3565.R012 | Right | 12 | M12 | 32 | 22,17 | 16 | 12,00 | 54 | 92 |
| R3565.R014 | Right | 14 | M14 | 36 | 25,35 | 19 | 13,50 | 60 | 127 |
| R3565.R016 | Right | 16 | M16 | 42 | 28,52 | 21 | 15,00 | 66 | 202 |
| R3565.R018 | Right | 18 | M18x1,5* | 46 | 31,70 | 23 | 16,50 | 72 | 250 |
| R3565.R020 | Right | 20 | M20x1,5* | 50 | 34,87 | 25 | 18,00 | 78 | 327 |
| R3565.R022 | Right | 22 | M22x1,5* | 54 | 38,05 | 28 | 20,00 | 84 | 440 |
| R3565.R025 | Right | 25 | M24x2* | 60 | 42,80 | 31 | 22,00 | 94 | 630 |
| R3565.R030 | Right | 30 | M30x2* | 70 | 50,75 | 37 | 25,00 | 110 | 1015 |
| R3565.L005 | Left | 5 | M5 | 18 | 11,06 | 8 | 6,00 | 33 | 14 |
| R3565.L006 | Left | 6 | M6 | 20 | 12,65 | 9 | 6,75 | 36 | 20 |
| R3565.L008 | Left | 8 | M8 | 24 | 15,85 | 12 | 9,00 | 42 | 38 |
| R3565.L010 | Left | 10 | M10 | 28 | 19,00 | 14 | 10,50 | 48 | 60 |
| R3565.L012 | Left | 12 | M12 | 32 | 22,17 | 16 | 12,00 | 54 | 92 |
| R3565.L014 | Left | 14 | M14 | 36 | 25,35 | 19 | 13,50 | 60 | 127 |
| R3565.L016 | Left | 16 | M16 | 42 | 28,52 | 21 | 15,00 | 66 | 202 |
| R3565.L018 | Left | 18 | M18x1,5* | 46 | 31,70 | 23 | 16,50 | 72 | 250 |
| R3565.L020 | Left | 20 | M20x1,5* | 50 | 34,87 | 25 | 18,00 | 78 | 327 |
| R3565.L022 | Left | 22 | M22x1,5* | 54 | 38,05 | 28 | 20,00 | 84 | 440 |
| R3565.L025 | Left | 25 | M24x2* | 60 | 42,80 | 31 | 22,00 | 94 | 630 |
| R3565.L030 | Left | 30 | M30x2* | 70 | 50,75 | 37 | 25,00 | 110 | 1015 |

| Order No. | l | l ₃ | a ₁ ° | a ₂ ° | Max. dyn load C (N) | Max static load C ₀ (N) |
|------------|----|----------------|------------------|------------------|---------------------|------------------------------------|
| R3565.R005 | 20 | 9 | 13,0 | 7,5 | 2400 | 3500 |
| R3565.R006 | 22 | 12 | 13,0 | 6,5 | 2820 | 4900 |
| R3565.R008 | 25 | 15 | 14,5 | 7,5 | 4280 | 8800 |
| R3565.R010 | 29 | 15 | 13,5 | 8,0 | 6400 | 14000 |
| R3565.R012 | 33 | 19 | 13,0 | 8,0 | 7600 | 20300 |
| R3565.R014 | 36 | 20 | 16,0 | 9,5 | 9480 | 27600 |
| R3565.R016 | 40 | 22 | 15,5 | 8,5 | 13760 | 37700 |
| R3565.R018 | 44 | 25 | 15,0 | 9,5 | 16160 | 46500 |
| R3565.R020 | 47 | 28 | 14,5 | 9,0 | 18960 | 54800 |
| R3565.R022 | 51 | 26 | 15,5 | 10,0 | 23480 | 63600 |
| R3565.R025 | 57 | 30 | 15,0 | 10,0 | 27860 | 79100 |
| R3565.R030 | 66 | 35 | 17,0 | 10,5 | 33800 | 97100 |
| R3565.L005 | 20 | 9 | 13,0 | 7,5 | 2400 | 3500 |
| R3565.L006 | 22 | 12 | 13,0 | 6,5 | 2820 | 4900 |
| R3565.L008 | 25 | 15 | 14,5 | 7,5 | 4280 | 8800 |
| R3565.L010 | 29 | 15 | 13,5 | 8,0 | 6400 | 14000 |
| R3565.L012 | 33 | 19 | 13,5 | 8,0 | 7600 | 20300 |
| R3565.L014 | 36 | 20 | 16,0 | 9,5 | 9480 | 27600 |
| R3565.L016 | 40 | 22 | 15,5 | 8,5 | 13760 | 37700 |
| R3565.L018 | 44 | 25 | 15,0 | 9,5 | 16160 | 46500 |
| R3565.L020 | 47 | 28 | 14,5 | 9,0 | 18960 | 54800 |
| R3565.L022 | 51 | 26 | 15,5 | 10,0 | 23480 | 63600 |
| R3565.L025 | 57 | 30 | 15,0 | 10,0 | 27860 | 79100 |
| R3565.L030 | 66 | 35 | 17,0 | 10,5 | 33800 | 97100 |

Rod Ends

Low Cost Rod Ends - Male Stainless Steel



R3577

y

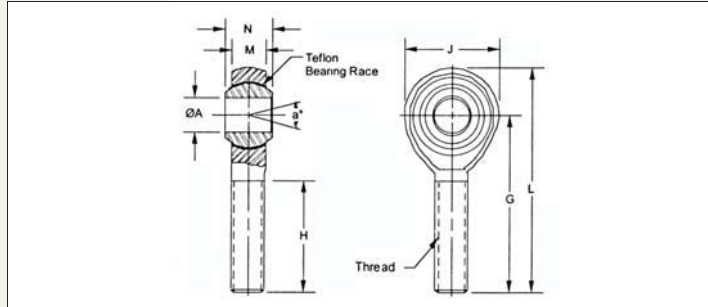

Material

Housing: 300 series **Stainless Steel**
Ball: Heat treated, **Stainless Steel**.
Race: teflon or PTFE liner.

Technical Notes

Male thread.

Standard thread is Right hand thread.

The ultimate load capacity is based upon the minimum mechanical properties of the design configuration in the stressed area.

The ultimate radial static load capacity in the rod end specification is defined as a single cycle, unidirectional applied load will cause ultimate failure. Operating loads should be based on the static load ratings, incorporating

appropriate safety factors to suit the application.

When a rod end is to be applied in full rotation, up to a maximum of 100 RPM, the operating loads should not exceed 10% of the ultimate radial static load.

| Order No. | Thread (hand) | Thread | A | a° | G | H | J | L | M | N | Ultimate radial static load (N) |
|------------|---------------|--------|----|----|----|----|------|-------|-------|----|---------------------------------|
| R3577.R006 | Right | M6 | 6 | 26 | 36 | 21 | 20,5 | 46,5 | 6,75 | 9 | 5218 |
| R3577.R008 | Right | M8 | 8 | 26 | 42 | 25 | 24,5 | 54,5 | 9 | 12 | 6954 |
| R3577.R010 | Right | M10 | 10 | 26 | 48 | 28 | 28,5 | 62,5 | 10,50 | 14 | 10,431 |
| R3577.R012 | Right | M12 | 12 | 26 | 54 | 32 | 32,5 | 70,5 | 12 | 16 | 13,040 |
| R3577.R020 | Right | M20 | 20 | 30 | 78 | 45 | 50,5 | 103,5 | 18 | 25 | 35,545 |

Rod ends with integral maintenance-free spherical plain bearings R3550, R3551, R3553, R3554, R3565, R3566

In many cases heavy-duty rod ends with integrated spherical plain bearings serve their purpose. They are above all used for small swivelling or tilting movements at low speeds. They stand out for their high loadability and can also be used for shocklike loads. The rod end ball slides on a plastic bearing shell consisting of a glass fibre-filled nylon/ teflon compound. This design assures an absolutely maintenance-free rod end.

Heavy-duty plain bearing rod ends have a slight initial stress and virtually no clearance. The plastic material used has a favourable secondary advantage in that it absorbs any foreign particles and encloses them so that no damage can occur. The joint balls of heavy-duty rod ends with integrated spherical plain bearings are standardly fitted with hard chrome plating. This reliable corrosion protection ensures that the function of the rod end will not be affected by a corroded ball surface under humid operating conditions.

Rod ends with integral self-aligning ball bearings R3556, R3557, R3559, R3560

This design is especially suitable for high speeds, large swivelling angles or rotating movements with relatively low or medium loads. Prominent technical features are the low bearing friction, long-time greasing as well as the sealing against rough dirt penetration by means of shields on both sides. Under normal operating conditions the rod ends are maintenance-free.

Greasing nipples are provided for lubrication in case of rough operations and maximum loads. To avoid incompatibility with the production lubrication, we recommend lubrication with a calcium-complex-soap-grease.

A special heat treatment procedure gives the rod end housing a raceway hardness adapted to the antifriction bearing, ensuring at the same time high stability with changing loads.

Rod ends with integral self-aligning roller bearings R3562, R3563

The design based on the structure of a self-aligning roller bearing is preferably used for high speed, large tilting angles or rotating movements under high loads. Compared to rod ends with self-aligning ball bearings, rod ends with self-aligning roller bearings have essentially higher basic load ratings. This design is equipped with a cage to minimise the rolling friction and heat build-up. These rod ends with long-time lubrication are under normal operating conditions maintenance-free.

Greasing nipples are provided for lubrication in case of rough operations and maximum loads. To avoid incompatibility with the production lubrication, we recommend lubricating with a calcium-complex-soap-grease.

Shields on both sides prevent dirt particles from penetrating into the bearing. The rod ends with self-aligning roller bearings are, just as the design with the self-aligning ball bearings, subjected to a special heat treatment to obtain a raceway hardness adapted to the antifriction bearings, ensuring at the same time a high stability with changing loads.

Basic load ratings

Static basic load rating of anti-friction bearing rod ends

The static basic load rating C_0 of an antifriction bearing rod end corresponds to that of a static radial load causing a lasting overall deformation of 1/10,000 of the roller body diameter at the contact point most highly stressed between roller body and raceway.

Static basic load ratings of plain bearing rod ends

The static basic load rating C_0 of a plain bearing rod end corresponds to that of static radial load that does not

yet cause a lasting deformation at the weakest housing section. It contains at least a 1,2 fold security compared to the yield stress of the material used for the rod end housing.

Dynamic basic load rating of antifriction bearing rod ends

The dynamic basic load rating C of an antifriction bearing rod end is the external radial load, unchangeable in size and direction, at which 90% of a large quantity of obviously identical rod ends will reach or exceed 1 million of rotations or swivelling movements.

Dynamic basic load ratings of plain bearing rod ends

The dynamic basic load rating C is the parameter for the calculation of dynamically loaded maintenance-free heavy-duty rod ends with integrated spherical plain bearing, in other words, making tilting, swivelling or rotating movements under load.

Basic load ratings always depend on the definitions they are based on. For this reason it is not always possible to compare basic load rating data supplied by different manufacturers.



Operating temperatures

Heavy-duty antifriction bearing rod ends can be used for operating temperatures between -20°C and $+120^{\circ}\text{C}$. The temperature range of heavy-duty rod ends with integral spherical plain bearing is between -30°C and $+60^{\circ}\text{C}$, without affecting the loadability. Higher temperatures will reduce the loadability taken into account for the calculation of the 'working life' under the temperature factor C2.

Loads

The decisive parameters for the selection and calculation of heavy-duty rod ends are size, direction and type of load.

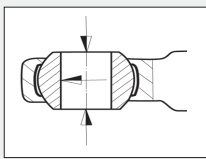

Radial or combined loads

The heavy-duty rod ends have been especially designed to adopt high radial loads. They can furthermore be used for combined loads, the axial load

share of which does not exceed 20% of the corresponding radial load.

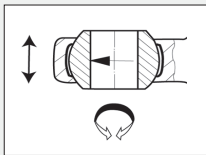

Unilaterally acting load

In this case the load acts only in the same direction, which means that the load area is always in the same bearing section.

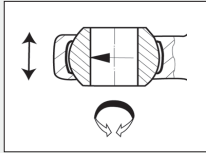

Alternately acting load

In case of alternating loads, the load areas facing each other are alternately loaded and / or relieved, which means that the load changes its direction

constantly by approximately 180° .

Swivelling angle

The swivelling angle is the excursion of the rod end from one final position to the other. Half the swivelling angle β is used to calculate the service or 'working life'.

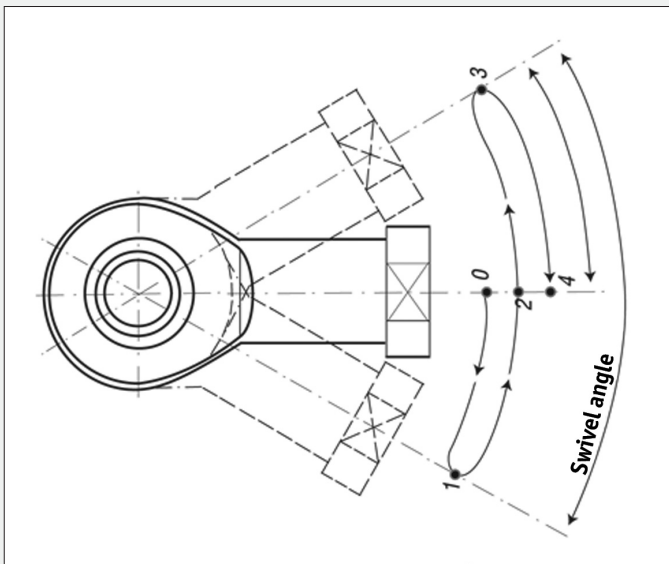

Angle of tilt

The angle of tilt, also called setting angle, refers to the possible excursion of the joint ball and/ or the inner ring to the rod end axis in degrees. The tilting angle a indicated in the table for the heavy-duty antifriction bearing rod ends corresponds to the maximum possible excursion being limited by the shields on both sides. It is important that this tilting angle is not exceeded either during installation or operation, as otherwise the shields may be damaged. As far as heavy-duty plain bearing rod ends are concerned, distinction is made between the tilting angles a_1 and a_2 .

If the excursion is not limited by adjacent components, excursion angle 1 can fully be used without affecting the rod end capacity. Tilting angle a_2 is the excursion limit when connecting a forked component.

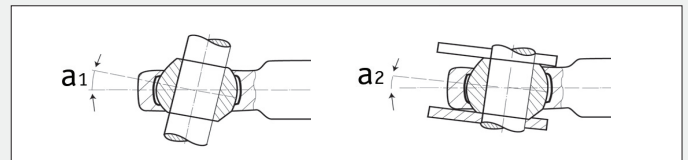

Nominal service life

The term 'nominal service life' is used for heavy-duty antifriction bearing rod ends and represents the number of swivelling motions or rotations and/ or the number of service hours the rod end performs before showing the first signs of material fatigue at the raceway or roller bodies. In view of many influence factors that are difficult or impossible to assess, the service life of several obviously identical bearings differ under the same operating conditions. For this reason, the following method for the service life determination of heavy-duty antifriction rod ends results in a nominal service life being achieved or exceeded by at least 90% of a larger quantity of identical rod ends.

Working life

The term 'working life' is used with heavy-duty plain bearing rod ends. It represents the number of swivelling motions or rotations and/ or the number of service hours the heavy-duty plain bearing rod end performs before becoming unserviceable because of material fatigue, wear, increased bearing clearance or increase of the bearing friction moment. The 'working life' is not only influenced by the size and the type of load, it is also affected by a number of factors, which are partially difficult to assess. A calculation of the exact service life is therefore impossible. Field-experienced standard values for the approximate 'working life' can nevertheless be determined by using the following calculation procedure which is based on numerous results from endurance test runs and values from decades of experience. The values determined by this formula are achieved, if not exceeded, by the majority of the heavy-duty rod ends.

Rod Ends

Technical Data/Tolerances

Heavy-duty rod ends (R3550, R3551, R3556, R3557, R3562, R3563, R3565, R3566)

| d1 | | d1mp tolerance limit | | V _{d1p} | V _{d1mp} | b1s tolerance limit | | hs, h1s, h2s tolerance limit | |
|------|------|----------------------|-------|------------------|-------------------|---------------------|-------|------------------------------|-------|
| over | icl. | upper | lower | max. | max. | upper | lower | upper | lower |
| | 6 | +0,012 | 0 | 0,012 | 0,009 | 0 | -0,12 | +0,8 | -1,2 |
| 6 | 10 | +0,015 | 0 | 0,015 | 0,011 | 0 | -0,12 | +0,8 | -1,2 |
| 10 | 18 | +0,018 | 0 | 0,018 | 0,014 | 0 | -0,12 | +1,0 | -1,7 |
| 18 | 30 | +0,021 | 0 | 0,021 | 0,016 | 0 | -0,12 | +1,4 | -2,1 |
| 30 | 50 | +0,025 | 0 | 0,025 | 0,019 | 0 | -0,12 | +1,8 | -2,7 |

Heavy-duty rod ends (R3553, R3554, R3559, R3560)

| d1 | | d1mp tolerance limit | | V _{d1p} | V _{d1mp} | b1s tolerance limit | | hs, h1s, h2s tolerance limit | |
|------|------|----------------------|--------|------------------|-------------------|---------------------|-------|------------------------------|-------|
| over | icl. | upper | lower | max. | max. | upper | lower | upper | lower |
| | 10 | +0,002 | -0,010 | 0,008 | 0,006 | 0 | -0,12 | +0,8 | -1,2 |
| 10 | 18 | +0,003 | -0,011 | 0,008 | 0,006 | 0 | -0,12 | +0,8 | -1,2 |
| 18 | 30 | +0,003 | -0,013 | 0,010 | 0,008 | 0 | -0,12 | +1,0 | -1,7 |
| 30 | 50 | +0,003 | -0,015 | 0,012 | 0,009 | 0 | -0,12 | +1,4 | -2,1 |
| 50 | 80 | +0,004 | -0,019 | 0,015 | 0,011 | 0 | -0,15 | +1,8 | -2,7 |

Dimension and tolerance symbols

| | |
|--|--|
| d ₁ | = nominal bore diameter of the inner ring or joint ball. |
| d _{1mp} | = mean bore diameter deviation in one pane, arithmetical mean of the largest and smallest bore diameter. |
| V _{d1p} | = bore diameter variation in one plane, difference between the largest and smallest bore diameter. |
| V _{d1mp} | = mean bore diameter variation, difference between the largest and smallest bore diameter of one inner ring or joint ball. |
| b _{1s} | = single inner ring or joint ball width deviation. |
| h, h ₁ , h ₂ | = single length from inner ring or ball bore centre to shank end. |
| h _s , h _{1s} , h _{2s} | = single length variation of a single rod end. |

Low cost rod ends

The ultimate load capacity is based upon the minimum mechanical properties of the design configuration in the stressed area.

The ultimate radial static load capacity in the rod end specification is defined as a single cycle, unidirectional applied load will cause ultimate failure.

Operating loads should be based on the static load ratings, incorporating appropriate safety factors to suit the application.

When a rod end is to be applied in full rotation, up to a maximum of 100 RPM, the operating loads should not exceed 10% of the ultimate radial static load.

Plastic Rod Ends

Technical Data



Load

The load capacity of the maintenance free bearing element parts is very high at normal ambient temperatures. These bearings absorb high forces and weigh only one fifth of traditional, metal bearing housings. The excellent dampening properties are based on the fact that the polymer material of the two part bearing can absorb vibrations differently than steel.

However, plastic specific properties, such as dependence on temperature and behaviour under long term stress must be taken into consideration when using these bearings. The load capacity of the rod end bearing should therefore be checked in a practical test, particularly if it will be used under continuous high loads and at elevated temperatures.

Chemical resistance

The moisture absorption is approximately 1.3% of weight in standard atmosphere. The saturation limit in water is 6.5%. This must be taken into account for these types of applications. The housing made of igumid G is resistant to weak alkalines, acids and fuels, as well as all types of lubricants.

| Medium | Resistance |
|---------------------------------|------------|
| Alcohol | + to 0 |
| Hydro carbons | + |
| Greases, oils without additives | + |
| Fuels | + |
| Diluted acids | 0 to - |
| Strong acids | - |
| Diluted alkalines | + |
| Strong alkalines | 0 |

Chemical resistance of plain bearings
+ resistant **0 conditionally resistant** **- not resistant**
All data given at room temperature (20°C)

Radiation resistance

Self aligning plain bearings are resistant to radiation up to an intensity of 3×10^2 Gy.

Application temperatures

These bearings can be used in temperatures from -30°C to + 80°C. The table below shows the effect of temperature on the load capacity of the bearings.

| | |
|---------------------|---------|
| Minimum | -30°C |
| Maximum, long term | + 80°C |
| Maximum, short term | + 120°C |

Coefficients of sliding friction and speed

One important advantage of plastic spherical bearings is that rapid, rotary movements of a mounted shaft take place directly in the spherical portion. In metallic rod ends, rotary motion takes place between the race and the spherical bearing. High speeds can be achieved with plastic bearings. These bearings are used in such a way that the angular movements of the spherical bearings take place at the outer diameter. By contrast, rotations of the shaft are supported directly in the I.D. of the spherical portion. The advantage therefore lies in the polymer vs. steel relationship. Polymer produces lower friction and permits high speeds, even when running dry.

UV resistance

The corrosion resistance of these bearings gives them special value for outside applications. They are permanently resistant to UV radiation. A small change in colour (dark colouration) of the spherical ball due to UV radiation does not affect the mechanical electrical or thermal properties.

